

WAN C/W

Designed by Johanna Grawunder, 2005

F9550009

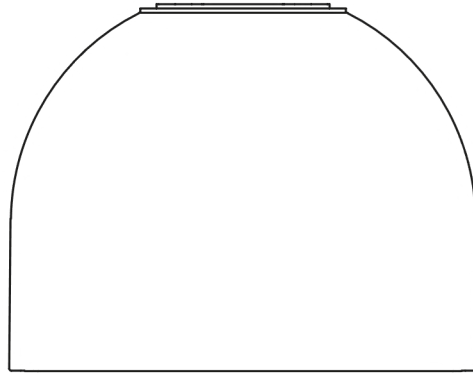

WAN C/W

F9550009

EN

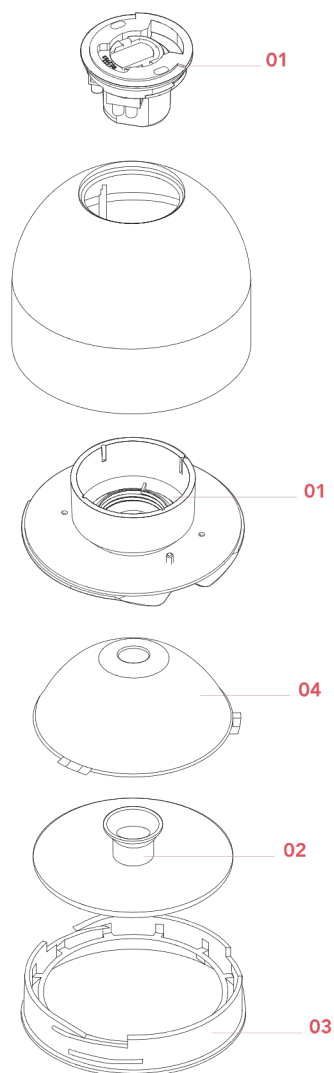

01. RF9550300 – N.T. attach. ass. with G9 lamp holder and safety ring

02. RF9550200 – Wan glass assembly

03. RF13990 – Black external ring

04. RF9550130 – Reflector with external black ring

WAN C/W F9550009

EN

RF9550300

NEW TYPE ATTACHMENT ASSEMBLY WITH G9 LAMP HOLDER AND SAFETY RING



WARNING! When installing and whenever acting on the appliance, ensure that the power supply has been switched off.
For the installation of the spare-part, it is necessary to consult a qualified electrician.

©2021 Flos - All rights reserved - www.flos.com
Flos reserves the right to introduce any changes to its own models, without prior notice.

WAN C/W F9550009

EN

RF9550300

NEW TYPE ATTACHMENT ASSEMBLY WITH G9 LAMP HOLDER AND SAFETY RING

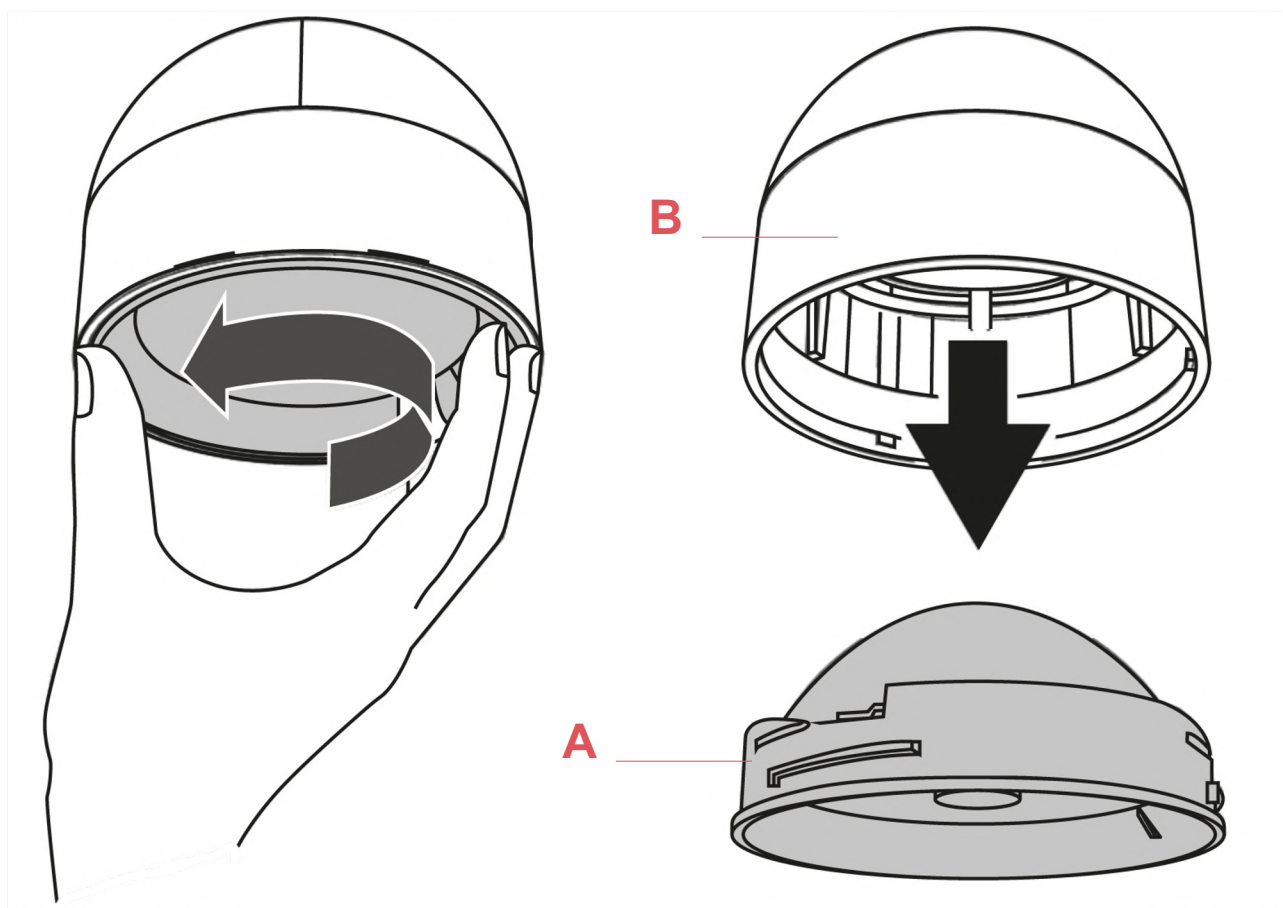

Fig.1

Remove the reflector/diffuser (A) from the lamp body (B) by slight rotating it anticlockwise.

WARNING! When installing and whenever acting on the appliance, ensure that the power supply has been switched off. For the installation of the spare-part, it is necessary to consult a qualified electrician.

WAN C/W F9550009

EN

RF9550300

NEW TYPE ATTACHMENT ASSEMBLY WITH G9 LAMP HOLDER AND SAFETY RING

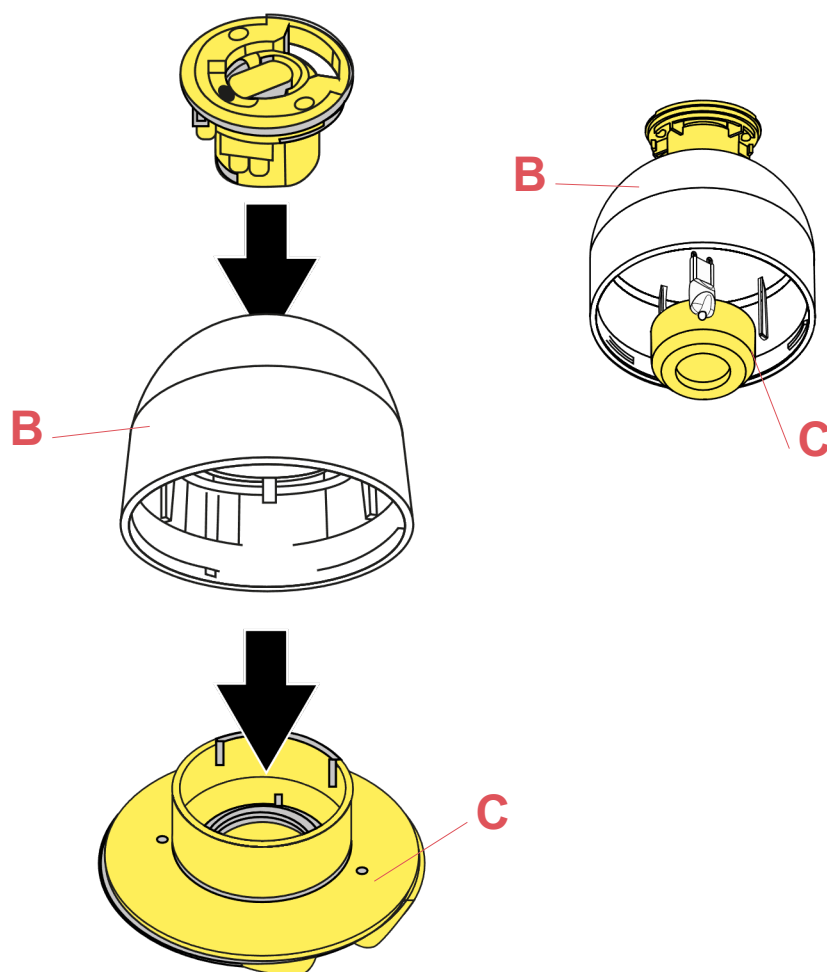

Fig.2

Remove the lamp bulb, unfasten the safety ring (C) and remove the lamp body (B).

WARNING! When installing and whenever acting on the appliance, ensure that the power supply has been switched off. For the installation of the spare-part, it is necessary to consult a qualified electrician.

WAN C/W F9550009

EN

RF9550300

NEW TYPE ATTACHMENT ASSEMBLY WITH G9 LAMP HOLDER AND SAFETY RING

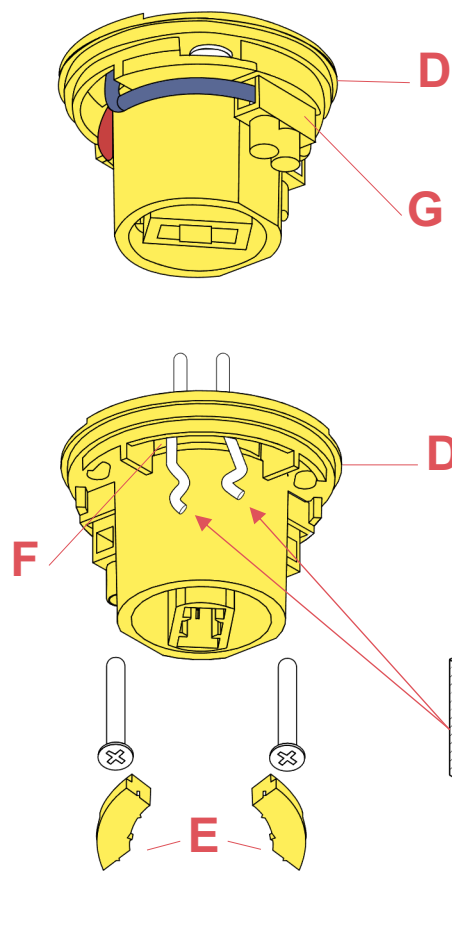

Fig.3

From the attachment (D) disconnect the electrical wires from the terminal box (G). Disassemble the screw covers (E), then remove the ceiling attachment (D) from the ceiling by unfastening using the screws and ensuring that the electric supply wires slide out of the hole (F).

Assemble now the new spare-part:

Disassemble the screw covers (E) and then fix the ceiling attachment (D) to the ceiling by utilizing the screws and plugs, ensuring that the electric supply wires pass through the hole (F).

REMARK: Select and employ screw anchors and plugs which are suited to the surface where the appliance is to be installed.

Cover the screws with there appropriate covers (E).

Slide the sheaths (I) onto the electric wires.

Connect the electrical wires to the terminal box (G) present on the ceiling attachment (D).

WARNING! When installing and whenever acting on the appliance, ensure that the power supply has been switched off. For the installation of the spare-part, it is necessary to consult a qualified electrician.

WAN C/W F9550009

EN

RF9550300

NEW TYPE ATTACHMENT ASSEMBLY WITH G9 LAMP HOLDER AND SAFETY RING

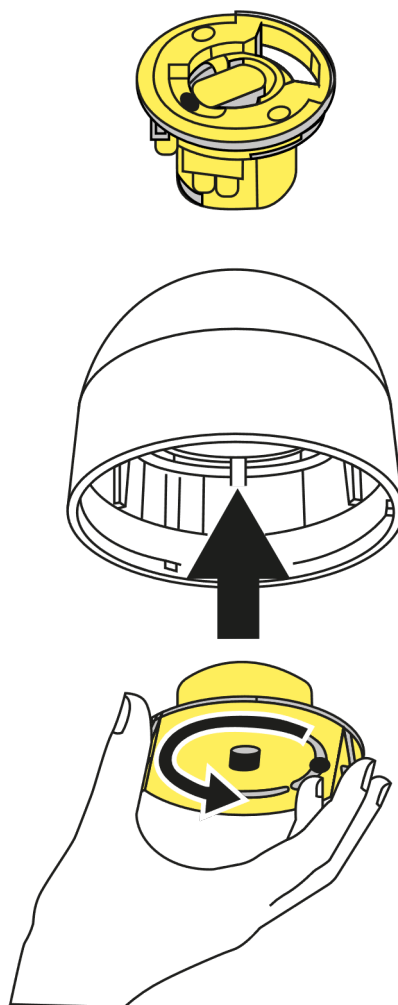

Fig.4

Re-assemble the device by inserting the lamp-bulb, then positioning the lamp body (B) and locking it through the safety ring (C).

WARNING! When installing and whenever acting on the appliance, ensure that the power supply has been switched off. For the installation of the spare-part, it is necessary to consult a qualified electrician.

WAN C/W F9550009

EN

RF9550300

NEW TYPE ATTACHMENT ASSEMBLY WITH G9 LAMP HOLDER AND SAFETY RING

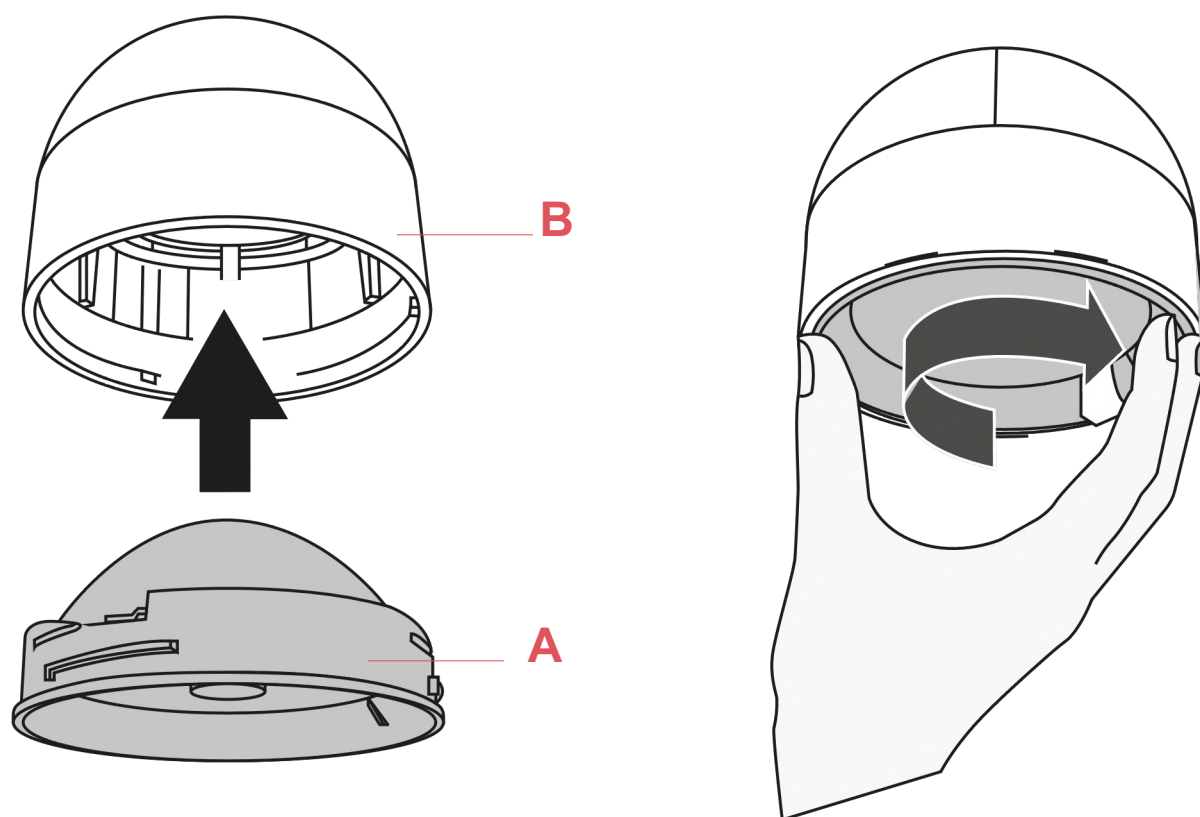

Fig.5

Remove the reflector/diffuser (A) from the lamp body (B) by slight rotating it anticlockwise.

WARNING! When installing and whenever acting on the appliance, ensure that the power supply has been switched off.
For the installation of the spare-part, it is necessary to consult a qualified electrician.

©2021 Flos - All rights reserved - www.flos.com
Flos reserves the right to introduce any changes to its own models, without prior notice.

WAN C/W F9550009

EN

RF9550200

WAN GLASS ASSEMBLY



Wan C/W
p.09



Wan S
p.13

WARNING! When installing and whenever acting on the appliance, ensure that the power supply has been switched off.
For the installation of the spare-part, it is necessary to consult a qualified electrician.

WAN C/W F9550009

EN

RF9550200

WAN GLASS ASSEMBLY

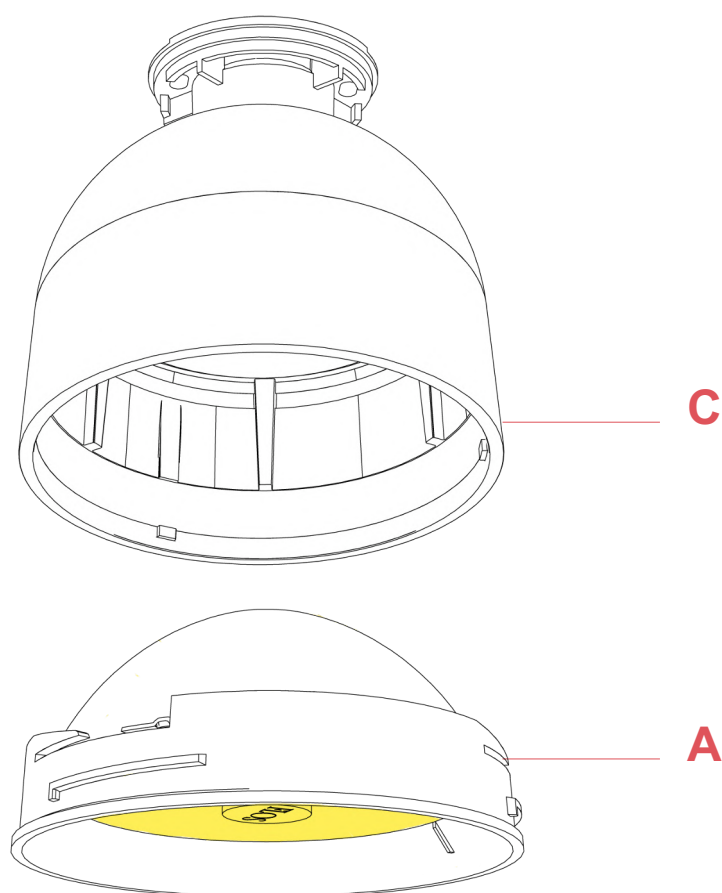

Fig.1

Remove the reflector/diffuser (A), unhooking it from the body (C) by slight rotating it anticlockwise.

WARNING! When installing and whenever acting on the appliance, ensure that the power supply has been switched off.
For the installation of the spare-part, it is necessary to consult a qualified electrician.

WAN C/W F9550009

EN

RF9550200

WAN GLASS ASSEMBLY



Fig.2



Fig.3

Remove the Reflector (B) from the damaged external ring (D).
Unlock the reflector (B) out from the safety locks (E).

WARNING! When installing and whenever acting on the appliance, ensure that the power supply has been switched off.
For the installation of the spare-part, it is necessary to consult a qualified electrician.

©2021 Flos - All rights reserved - www.flos.com
Flos reserves the right to introduce any changes to its own models, without prior notice.

WAN C/W F9550009

EN

RF9550200

WAN GLASS ASSEMBLY



Fig.4



Fig.5

Remove the Reflector (B) from the damaged external ring (D).

Assemble now the new spare-part:

Position the glass diffuser (F) on top of the external ring (D).

WARNING! When installing and whenever acting on the appliance, ensure that the power supply has been switched off. For the installation of the spare-part, it is necessary to consult a qualified electrician.

WAN C/W F9550009

EN

RF9550200

WAN GLASS ASSEMBLY



Fig.6



Fig.7

Position the reflector (B) on top of the external ring (D).
Lock the reflector (B) inside the safety lock system (E).

Assemble the reflector/diffuser assembly (A), by hooking it on the lamp body (C) rotating it clockwise. (Fig.1 page 10)

WARNING! When installing and whenever acting on the appliance, ensure that the power supply has been switched off.
For the installation of the spare-part, it is necessary to consult a qualified electrician.

WAN C/W F9550009

EN

RF13990

EXTERNAL RING



Wan C/W
p.14



Wan S
p.18

WARNING! When installing and whenever acting on the appliance, ensure that the power supply has been switched off.
For the installation of the spare-part, it is necessary to consult a qualified electrician.

WAN C/W F9550009

EN

RF13990

EXTERNAL RING

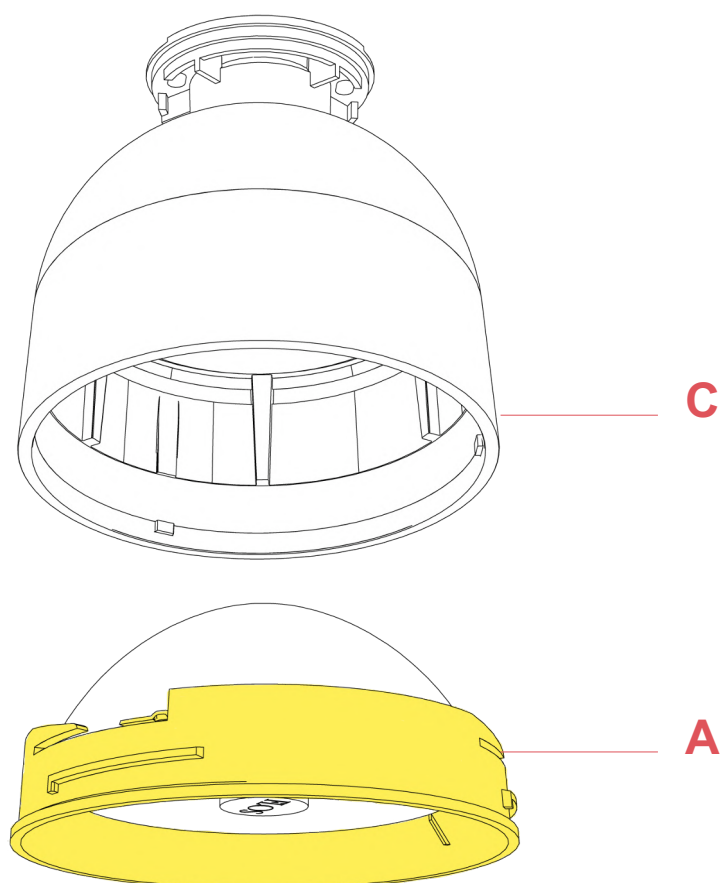

Fig.1

Remove the reflector/diffuser (A), unhooking it from the body (C) by slight rotating it anticlockwise.

WARNING! When installing and whenever acting on the appliance, ensure that the power supply has been switched off. For the installation of the spare-part, it is necessary to consult a qualified electrician.

WAN C/W F9550009

EN

RF13990

EXTERNAL RING



Fig.2



Fig.3

Remove the Reflector (B) from the damaged external ring (D).
Unlock the reflector (B) out from the safety locks (E).

WARNING! When installing and whenever acting on the appliance, ensure that the power supply has been switched off.
For the installation of the spare-part, it is necessary to consult a qualified electrician.

©2021 Flos - All rights reserved - www.flos.com
Flos reserves the right to introduce any changes to its own models, without prior notice.

WAN C/W F9550009

EN

RF13990

EXTERNAL RING



Fig.4



Fig.5

Remove the glass diffuser (F) from the damaged external ring (D).

Assemble now the new spare-part:

Position the glass diffuser (F) on top of the external ring (D).

WARNING! When installing and whenever acting on the appliance, ensure that the power supply has been switched off. For the installation of the spare-part, it is necessary to consult a qualified electrician.

WAN C/W F9550009

EN

RF13990

EXTERNAL RING



Fig.6



Fig.7

Position the reflector (B) on top of the external ring (D).

Lock the reflector (B) inside the safety lock system (E).

Assemble the reflector/diffuser assembly (A), by hooking it on the lamp body (C) rotating it clockwise. (Fig. 1 page 15).

WARNING! When installing and whenever acting on the appliance, ensure that the power supply has been switched off.
For the installation of the spare-part, it is necessary to consult a qualified electrician.

WAN C/W F9550009

EN

RF9550130

REFLECTOR / RING ASSEMBLY



Wan C/W
p.19



Wan S
p.23

WARNING! When installing and whenever acting on the appliance, ensure that the power supply has been switched off.
For the installation of the spare-part, it is necessary to consult a qualified electrician.

WAN C/W F9550009

EN

RF9550130

REFLECTOR / RING ASSEMBLY

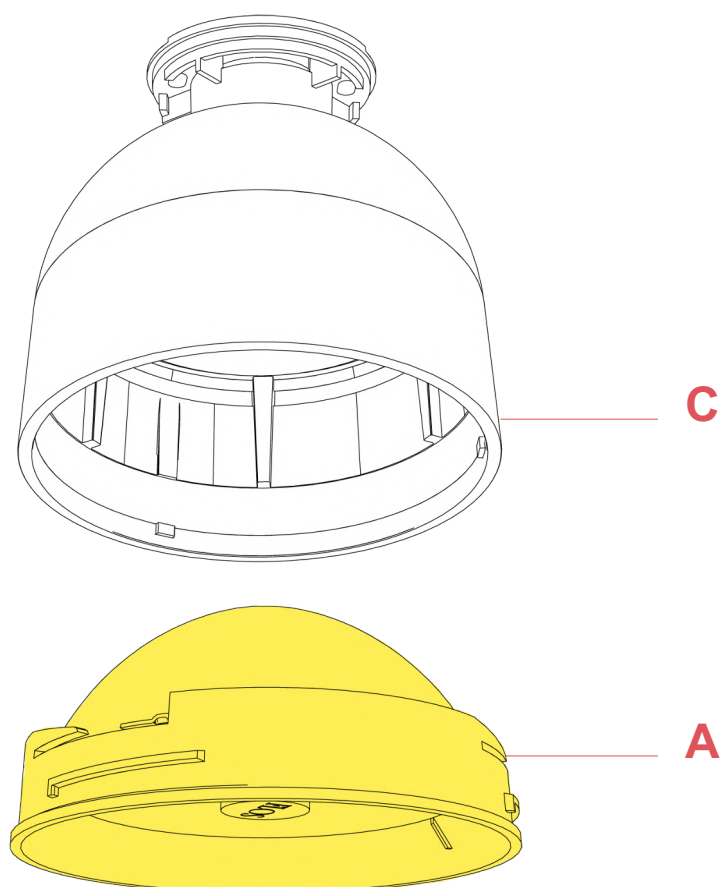

Fig.1

Assemble the reflector/diffuser assembly (A), by hooking it on the lamp body (C) rotating it clockwise.

WARNING! When installing and whenever acting on the appliance, ensure that the power supply has been switched off. For the installation of the spare-part, it is necessary to consult a qualified electrician.